

Datasheet Grenton Electro-thermal Actuator ACC-014-R-12

ELECTRO-THERMAL ACTUATOR in the NC configuration (Normally Closed). The actuator opens when it is powered by 24V. It enables precise control of the room temperature by controlling the supply of hot water to the radiator.



1. Technical data

Electrical properties:	
Supply voltage	24 V AC/DC
Maximal device current (ON state)	250 mA/1.20s
Maximal power consumption (ON state)	2 W
Default state (without power)	NC - normally closed

Properties:	
Installation	vertical, top-down
Thread	M30 x 1,5
Force	100 N +/-10%
Valve opening time	2 min
Stroke length	4 mm
Dimensions	fi: 39 mm, height: 69,5 mm
Operating temperature range	5 - 60 °C
Enclosure	IP54
Standards	EN 60730-2-8: 2002 + A1:2003 / EN 60730-1: 2016

2. Installation

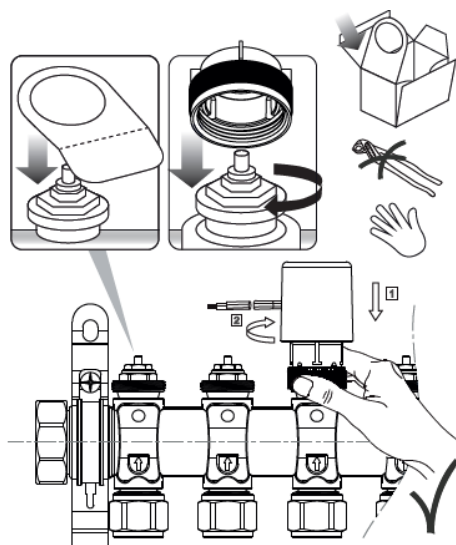

3. Principle of operation

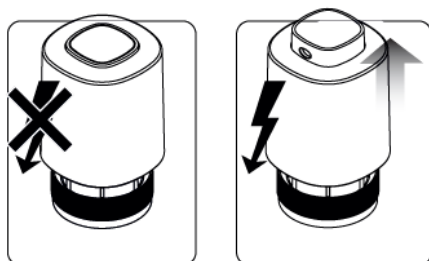

4. Function "First Open"

This ELECTRO-THERMAL ACTUATOR is made in the NC configuration (Normally Closed). To allow liquid to flow through the heating system it is necessary to supply the voltage (230 V_{ac}) to the actuator. The "First Open" function allows the heating system to

operate by opening the actuator during the setup and installation phase without the need to supply the device with the rated voltage.

NC - NORMALLY CLOSED "First Open"

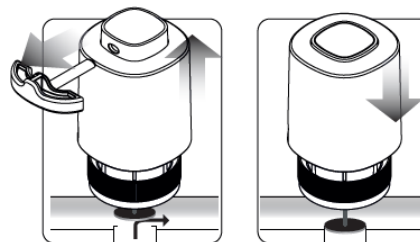

5. Warnings and cautionary statements



ATTENTION!

- Before proceeding with the assembly, read the installation schematics and full instructions available at www.grenton.com. Failure to follow the guidelines contained in the instructions and other requirements of due care valid as a result of the nature of the equipment (device) may be dangerous to life / health, damage the device or installation to which it is connected, damage other property or violate other applicable

regulations. The manufacturer of the device and Grenton Sp. z o.o. does not bear any responsibility for the damage (property and non-property related) resulting from the assembly and / or use of the equipment not in accordance with the instructions and / or due diligence in handling the equipment (device).

- Device power supply, permissible load or other characteristic parameters have to be in accordance with the device specification, described in particular in the "Technical data" section.
- The product is not intended for children and animals.
- If you have technical questions or comments about the device operation, contact Grenton Technical Support.
- Answers to frequently asked questions can be found at: www.support.grenton.pl



DANGER!

- Danger to life caused by electric current!
- The components of the installation (individual devices) are designed to work in a home electrical installation or directly in its

vicinity. Incorrect connection or use may cause a fire or electric shock.

- All work related to the installation of the device, in particular works involving interference in the electrical installation, may be performed only by a person with appropriate qualifications or licences.
- When installing the device, make sure that the power supply voltage is disconnected from the circuit in which the device is connected or near which the assembly takes place.

6. CE marking

The manufacturer declares that the device is in full compliance with the requirements of EU legislation that includes the directives of a new approach appropriate for this equipment. In particular, Grenton Sp. z o.o. declares that the device fulfills the requirements on safety, specified by law, and that it conforms to

the national regulations that implement the appropriate directives: The Directive on the electromagnetic compatibility (EMC - 2014/30/UE) and the Directive on the limitation of the use of specific substances in electrical and electronic equipment (RoHS II - 2011/65/UE).



7. Warranty

Warranty available at: www.grenton.com/warranty

8. Manufacturer contact details

Manufactured for:	Manufacturer:	Distributor:
Grenton Sp. z o.o. Na Wierzchowinach 3 30-222 Kraków, Polska	SALUS Controls Plc Units 8-10 Northfield Business Park Forge Way, Parkgate, Rotherham S60 1SD, United Kingdom	QL Controls, Sp. z o.o, Sp.k., Rolna 4 43-262 Kobilice