

User Manual LED RGBW Z-Wave

RGB-201-Z-01

Grenton LED RGBW Z-Wave module allows for smooth control of LED lighting and halogen lighting using PWM signal, enables the connection of 2 digital inputs to the system, and supports the connection of one digital 1-Wire temperature sensor.



1. Technical data

Device power supply	12-24V _{dc}
Maximum power consumption	0,096W
Maximum device current	4mA (for 24V _{dc})
LED power supply (Vcc)	up to 24V _{dc}
Maximum load current RGBW	12A (total for all channels)
Maximum channel load current	4A
PWM output frequency	600Hz
Maximum number of 1-Wire sensors	1
Maximum wire cross section	1,5mm ²
Z-wave frequency	EU: 868,4MHz
Weight	22g
Fixing	flush mounted
Dimensions (H/W/D)	22/46/37mm
Operating temperature range	0 to +45°C

2. Wiring diagram

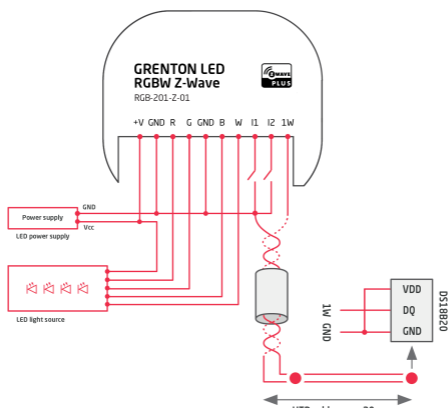

+V	Device power supply
GND	GND for +V, and "Red" and "Green" outputs
R	"Red" output
G	"Green" output
GND	GND for digital inputs, 1-Wire, and "Blue" and "White" outputs
B	"Blue" output
W	"White" output
I1	first digital input
I2	second digital input
1W	1-Wire input

3. Module Inclusion

To add the device to the Z-Wave network:

1. Connect the module according to the diagram above.
2. Set your Z-Wave controller into inclusion mode.
3. Generate quickly¹ 6 pulses on I1 input. The status LED starts blinking with a period of 500ms.
4. The status LED turns off at the end of the Inclusion process.

If you are connecting this unit to a Z-Wave Controller that utilizes the S2 security protocol, you may be asked to enter the first 5 digits of Device Specific Key (DSK). You can find it on the label with QR code on the back of the unit.

The device supports SmartStart function. SmartStart enabled products can be added into a Z-Wave network by scanning the Z-Wave QR Code present on the product with a controller providing SmartStart inclusion. No further action is required and the SmartStart product will be added automatically within 10 minutes of being switched on in the network vicinity. The device provides DSK representation on the product, so you can add it manually to the controller.

4. Module Exclusion

To remove the device from the Z-Wave network:

1. Connect the module according to the diagram above.
2. Set your Z-Wave controller into exclusion mode.
3. Generate quickly¹ 6 pulses on I1 input. The status LED starts blinking with a period of 500ms.
4. The status LED turns off at the end of the Exclusion process.

5. Factory Reset

To restore factory configuration:

1. Connect the module according to the diagram above.
2. Generate quickly¹ 6 pulses on I2 input. The status LED turns on.
3. Generate quickly¹ 6 pulses on I1 input. The status LED turns off.

6. Standalone Mode

To enable/disable standalone mode:

1. Connect the module according to the diagram above.
2. Generate quickly¹ 6 pulses on I2 input. The status LED turns on.
3. Generate quickly¹ 4 pulses on I1 input. The status LED turns off.

7. Warnings and Cautionary Statements



ATTENTION I

- Before proceeding with the assembly, read the installation schematics and full instructions available at www.grenton.com. Failure to follow the guidelines contained in the instructions and other requirements of due care valid as a result of the nature of the equipment (device) may be dangerous to life / health, damage the device or installation to which it is connected, damage other property or violate other applicable regulations. The manufacturer of the device, Grenton Sp. z o.o. does not bear any responsibility

for the damage (property and non-property related) resulting from the assembly and / or use of the equipment not in accordance with the instructions and / or due diligence in handling the equipment (device).

- Device power supply, permissible load or other characteristic parameters have to be in accordance with the device specification, described in particular in the "Technical data" section.
- The product is not intended for children and animals.
- If you have technical questions or comments about the device operation, contact Grenton Technical Support.
- Answers to frequently asked questions can be found at: www.support.grenton.com.



DANGER I

- Danger to life caused by electric current!
- The components of the installation (individual devices) are designed to work in a home

electrical installation or directly in its vicinity. Incorrect connection or use may cause a fire or electric shock.

- All work related to the installation of the device, in particular works involving interference in the electrical installation, may be performed only by a person with appropriate qualifications or licences.
- When installing the device, make sure that the power supply voltage is disconnected from the circuit in which the device is connected or near which the assembly takes place.

8. CE Marking

The manufacturer declares that the device is in full compliance with the requirements of EU legislation that includes the directives of a new approach appropriate for this equipment. In particular, Grenton Sp. z o.o. declares that the device fulfills the requirements on safety, specified by law, and that it conforms to the na-

tional regulations that implement the appropriate directives: The Radio Equipment Directive (RED - 2014/53/UE) and the Directive on the limitation of the use of specific substances in electrical and electronic equipment (RoHS II - 2011/65/UE).



9. Warranty

Warranty available at www.grenton.com/warranty.

10. Manufacturer Contact Details

Grenton Sp. z o.o.
ul. Na Wierzchowinach 3
30-222 Kraków, Poland
www.grenton.com

¹ less then 200ms transition